

# 12

# Start and Charge Systems

▼ IN THIS ISSUE

<b>INTRODUCTION</b>	<b>2</b>	<b>CURRENT GENERATOR</b>	<b>8</b>		
<b>BATTERY</b>	<b>2</b>	<b>START&amp;STOP SYSTEM</b>	<b>9</b>	<b>COMMON FAULTS</b>	<b>16</b>
<b>STARTER MOTOR</b>	<b>3</b>	<b>REVERSIBLE ALTERNATOR</b>	<b>11</b>	<b>TECHNICAL NOTES</b>	<b>18</b>



EureTechFlash is an AD International publication (www.ad-europe.com)

Download all EureTechFlash editions at [www.eurecar.org](http://www.eurecar.org)

# INTRODUCTION

Vehicles powered by internal combustion engines require components that are capable of starting the engine, generating electricity and storing part of it. The parts responsible for these functions form the starting and charging systems, and carry out a discontinuous cycle of conversion of electrical to mechanical energy and vice versa. These systems allow the starting, running and stopping cycle to be carried out continuously and for it to be interrupted when required.

The starter motor converts electrical energy (supplied from the battery) into mechanical energy to rotate the engine until it starts. At the same time, so the engine can continue to run, an electrical current generator or alternator is required. The alternator, in contrast to the starter motor, converts mechanical energy (from the rotation of the engine) into electrical energy. Part of the electrical energy supplied by the alternator is stored in the battery and the rest supplies the vehicle's loads, among which is the engine itself. The electrical energy stored in the battery will be used to restart the engine and supply some of the vehicle's electrical circuits when the engine is stopped.

As a consequence of the evolution of anti-pollution regulations towards increasingly more restrictive values, the starting and charging system has undergone a significant evolution over recent years in order to contribute to the more efficient operation of the vehicle.

One of the most noticeable advances in this regard is the creation of the Start-Stop systems, which stop the engine during short stops, which are very common in urban traffic, and restart it automatically to continue driving. The latest generation charging systems also use the vehicle's kinetic energy during braking to produce electrical energy. This avoids generating it during acceleration phases in order to reduce fuel consumption without affecting the performance of the engine.

Recently, reversible alternator systems have also been developed, this specific component is key to "capturing" more energy during deceleration. It is also capable of starting the engine in the automatic stop phases, so the starter motor is not used in these cases. In more sophisticated models, the reversible alternator can even help the vehicle's engine during acceleration.

## BATTERY

The battery is the reserve energy source for the car's electrical systems. This accumulator stores the electrical energy provided by the generator in two chemical compounds of different electrical potential. During the dis-

charging process, the chemical conversions go in the opposite direction to those in the charging phase and supply electrical energy as a result of the decomposition of the previously formed substances.

## Architecture and components

The battery is made up of an external case with several internal separators that form physically isolated receptacles called cells. Normally batteries that are used for automotive purposes are divided into six cells, and each one of these provides a potential difference of 2 volts nominal. Each cell has two groups of alternate plates connected in such a way that one group forms the positive pole and the other the negative.

The electrical potential difference between the physically opposing plates generates the battery's electrical current. Each cell's set of plates are joined at the top at a single point, connected in parallel, while the cells are connected together in series to provide a total nominal voltage of 12 V. The

cells are full of electrolyte and the plates are submerged in it.

The electrolyte is the substance that allows the charging and discharging chemical reactions. It is made up of approximately 60% distilled water and 40% sulphuric acid.

The positive and negative terminals are located on the outer ends of the battery. These are the free conductors of the end cells. In the case of batteries that require maintenance, at the top of the case there are holes with caps that seal each cell. Distilled water can be added through the holes if necessary to compensate for evaporation, and thus maintain the chemical ratio of the electrolyte.

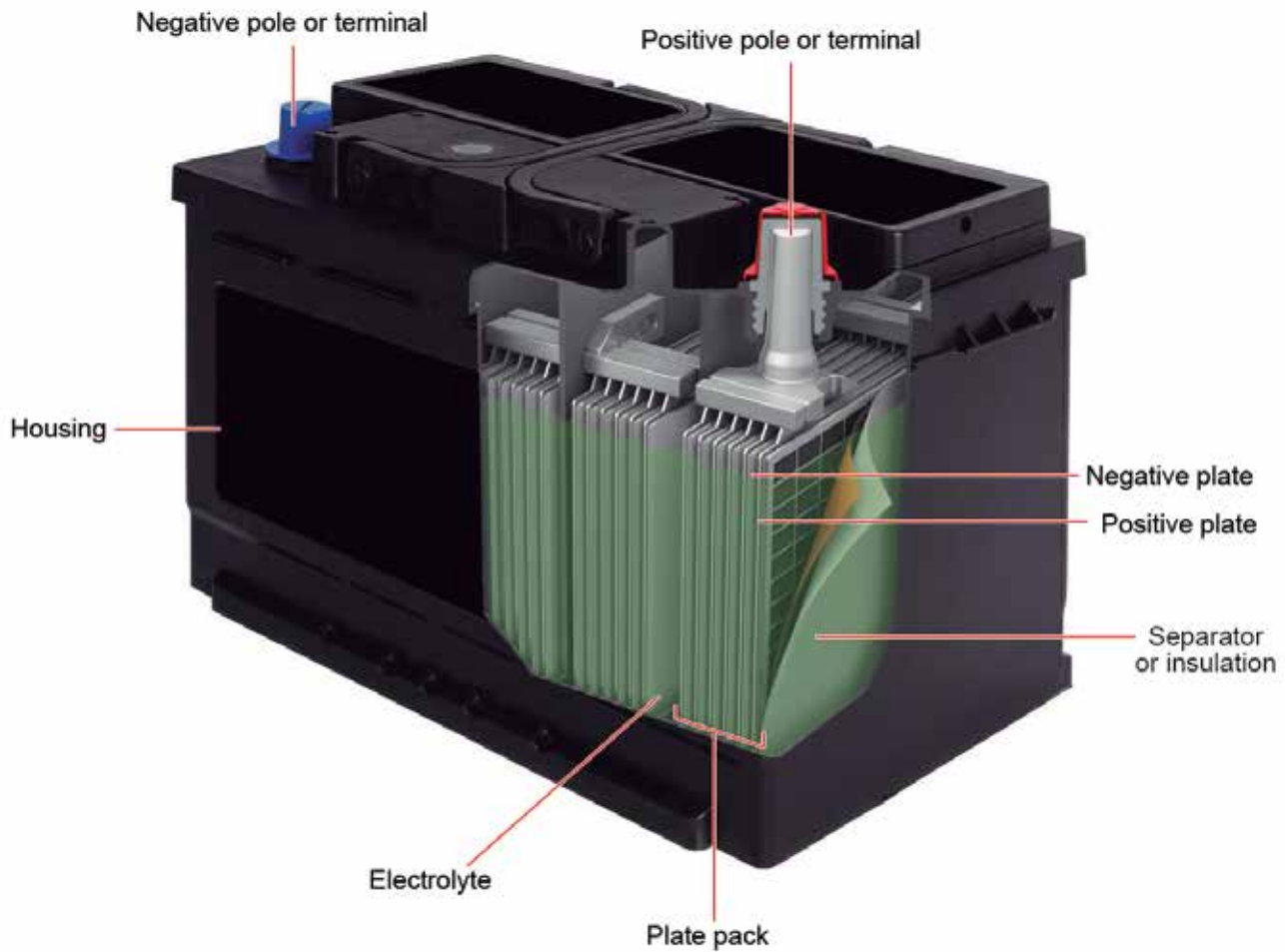

## Operating principle

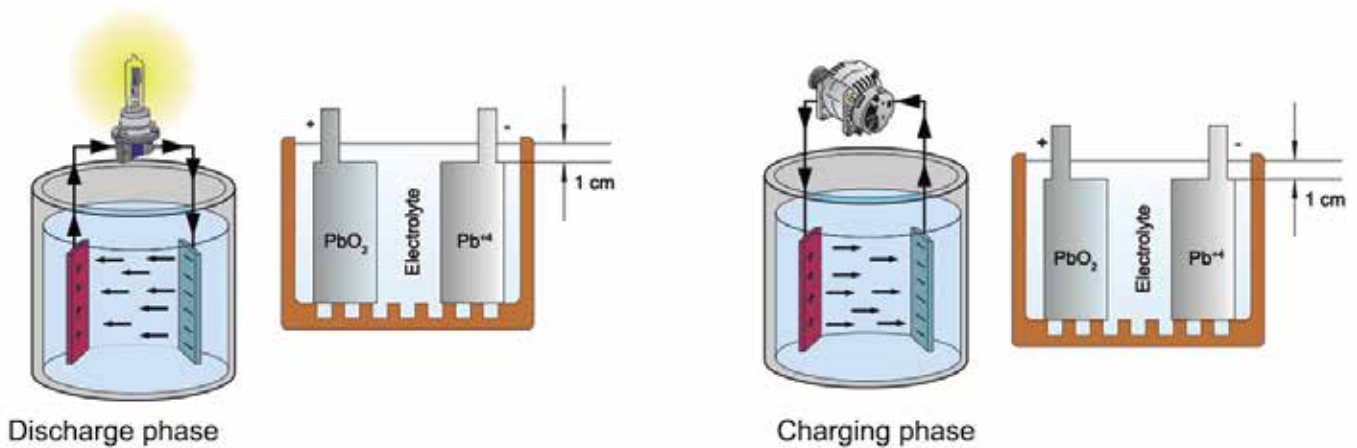

When the battery is connected to a load network, the difference of electrical potential between its two terminals or poles causes the flow of electrons that we know as electrical current. This continues until the potential of both terminals is equal (discharging), when the chemical composition of the substances is similar.

The alternator produces the potential difference and generates electrical energy that again disassociates these substances, thus re-establishing the unequal electrical potential between both terminals (charging).

The battery's repeated charging and discharging processes cause the progressive detachment of the active plate material which precipitates at the bottom of the cell. The accumulation of material at the bottom can eventually short-circuit the plates, for this reason, there are spaces provided at the bottom of the case for the accumulation of this material.

To lengthen the life of the battery, various different materials are used to coat the plates, reduce their internal wear and prevent their deformation.



## Electrical characteristics

The battery label indicates the main characteristics that must be known. Nevertheless, there are some additional concepts that must be taken into

consideration for the correct choice of battery suitable for each type of vehicle.



### Nominal voltage

This is the sum of the individual voltages of each cell. Car batteries use, generally, 6 cells of 2 volts each thus achieving a nominal voltage of 12 V. However, it must be taken into consideration that in a maximum state of charge of the battery, each cell can reach a maximum voltage of between

2.3 and 2.4 volts, so the total voltage (6 cells) adds up to between 13.8 and 14.4 volts.

### Nominal capacity

Specifies the electrical current that the battery is capable of continuously supplying over a period of 20 hours at a temperature of 25°C. This relationship between the electrical current and time is indicated in amps per hour (Ah), which is the electrical energy the battery can store. The battery

capacity depends on the number and size of the plates of each cell. The greater the size or amount, the greater the capacity. Thus a battery with a nominal capacity of 40 Ah can supply a current of 2 A for 20 hours continuously.

### Discharge current

This is the maximum instantaneous current that a battery can supply. This value is indicated in amps (A). The manufacturers determine this value in accordance with the current regulations, normally under very cold conditions (-18°C). In this case, the label in the image shows that the fully

charged battery can supply a maximum 640 A and maintain the nominal voltage of 12 V. This current must ensure the start-up of a combustion engine under extremely cold conditions.

## Types of batteries

### Wet batteries

Up to a few years ago, these were the most common due to their low cost and availability. They are called wet batteries because they contain liquid sulphuric acid in free movement. Their main disadvantages are the risk of spillage of the acid in case of accident and their low energy density (electrical capacity/volume ratio). There are two types of batteries in this group:

those that need their electrolyte level to be checked and corrected every so often through the cell caps, and maintenance-free batteries which usually use what is called a "magic eye" to show whether the electrolyte concentration is in an acceptable state or not, as they do not have cell caps.

### VRLA (Valve Regulated Lead Acid) battery

These are maintenance-free batteries. Each cell has a valve to manage the internal pressure which raises the boiling point and minimises water

evaporation, thus the electrolyte concentration and level is maintained stable during the useful life of the battery.

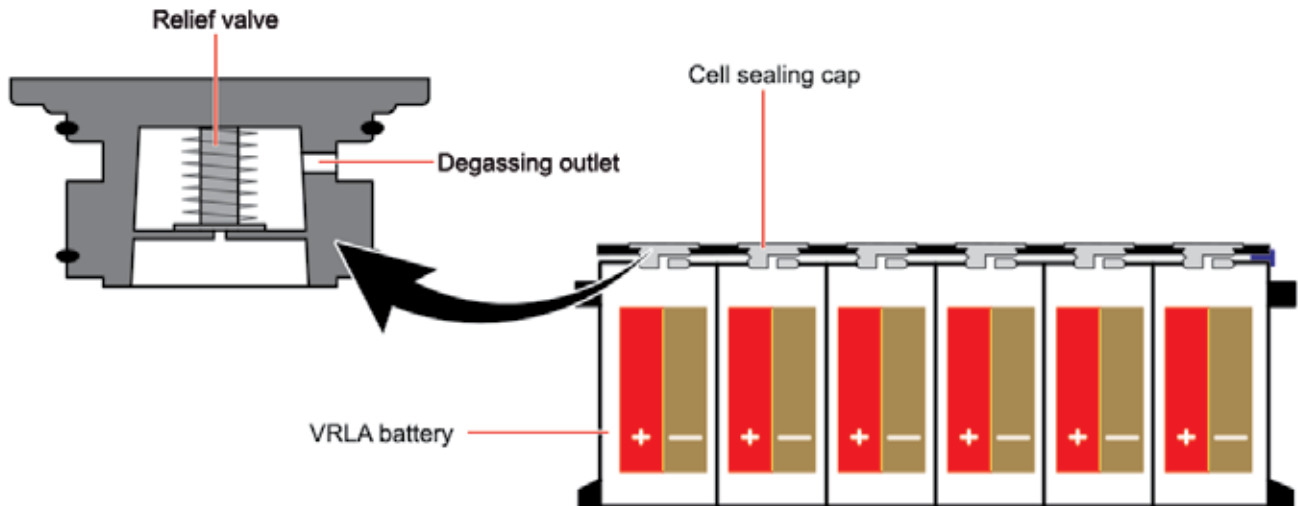

As they emit very low vapour levels, the VRLA batteries can be used in small spaces with little ventilation. Furthermore, as there is no spillage risk, they can be fitted in any orientation. The ratio between their energy density and cost is good, which means they can be used in vehicles with a high level of electrical equipment. These batteries are particularly sensitive to excess charging, therefore they need specific charging voltage limiters

that do not exceed a voltage of 14.4 volts. It should be borne in mind that there are old battery chargers on the market that are not compatible with VRLA batteries.

There are two main VRLA battery variants on the market:

- GEL batteries
- AGM Batteries

## GEL batteries

They use an electrolyte that includes silicic acid. This gives it a thick texture in the form of a gel. This increases safety in the event of a spillage and homogenises the charging and discharging cycles. They can be recharged even in the case of complete discharging. The drawbacks of these batteries are their higher cost and performance problems at both extreme low

and high temperatures, which does not make them suitable for use in vehicles that must provide service in extreme climates. For this reason, they are usually most suitable for marine use (stable climate), motorhomes (interior installation) and as solar energy accumulators (protected locations).

## AGM (Absorbent Glass Mat) Batteries

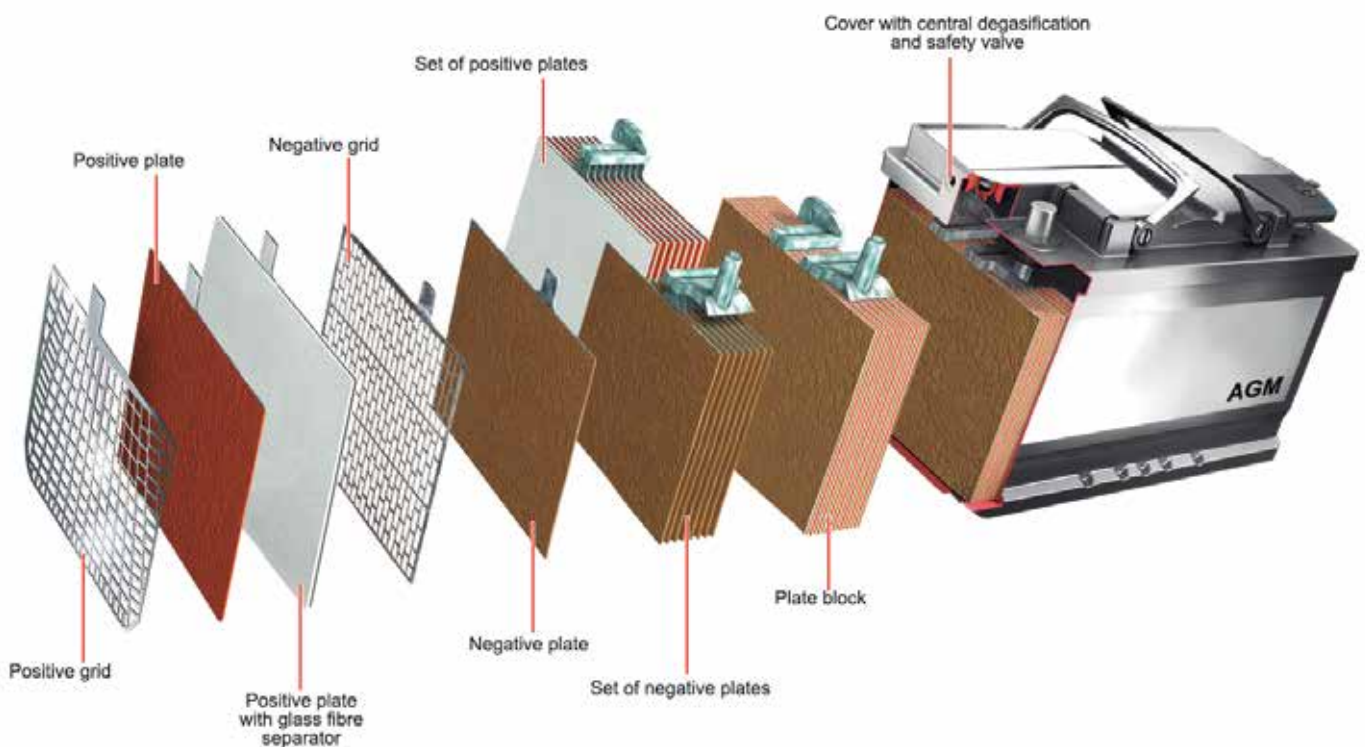

These are characterised by their use of an absorbent glass fibre mat to retain the electrolyte between the plates by preventing movement, therefore the acid is better assimilated and reacts more quickly. They also pose no spillage risk. It should be noted that AGM batteries have a very low internal resistance. This allows them to deliver and absorb higher current rates during the charging and discharging phases compared with other sealed batteries. Furthermore, they can respond to the energy demand in vehicles with a high level of electrical equipment more efficiently.

### VRLA (Valve Regulated Lead Acid) battery

These batteries use a lithium salt as the electrolyte in an organic solvent, which allows the passage of the necessary ions to produce the reversible electrochemical reaction between the cathode and anode of each cell. The advantages of lithium-ion batteries are: lightness due to their high energy density, resistance to self-discharge, a high power delivery capacity (due to their low internal resistance), a practically non-existent memory effect and a high number of charging and discharging cycles.

In the automotive industry, these batteries are principally used in plug-in hybrids and pure electric vehicles, and are classified as traction batteries. They work with voltages that can reach up to 400 V in some models. The charging and discharging voltages per cell in these batteries must be between the limits set by the manufacturer. This is done by incorporating an electronic management system which monitors and balances the charge/discharge cycles and their correct operation. Fur-

thermore, to improve energy efficiency, these batteries usually have an active cooling system which maintains the cells at an optimum working temperature.

Lithium-ion technology is not just used in traction batteries, but can also be applied in starter batteries. An example of this is the Hyundai Ionic hybrid, which uses two lithium polymer batteries: one of 12 V for the auxiliary function and another of 240 V for the starter and traction function.

Within the combustion engine vehicle category, there are also models, such as supercars and motorcycles, in which the conventional starter battery is replaced by a lithium-ion type battery (12 V) to reduce weight and improve performance. In contrast to traction batteries, these are smaller, work at low voltage and do not need an active cooling system or significant electronic management.

Within the combustion engine vehicle category, there are also models, such as supercars and motorcycles, in which the conventional starter battery is replaced by a lithium-ion type battery (12 V) to reduce weight and improve performance. In contrast to traction batteries, these are smaller, work at low voltage and do not need an active cooling system or significant electronic management.



## STARTER MOTOR

This is a direct current (battery) electric motor that helps the engine to turn over until the first combustion occurs and it runs on its own. It is located on the side of the flywheel, and its teeth engage with those of the toothed ring gear on the flywheel. The size, weight and current

consumption of the starter motor depends on its internal construction and the characteristics of the engine to be started, which principally depends on its cylinder capacity and fuel used.

## Architecture and components

A starter motor principally consists of an electric motor, a coupling relay, gear mechanism and disconnection by withdrawing.

### Electric motor

This is made up of the following elements:

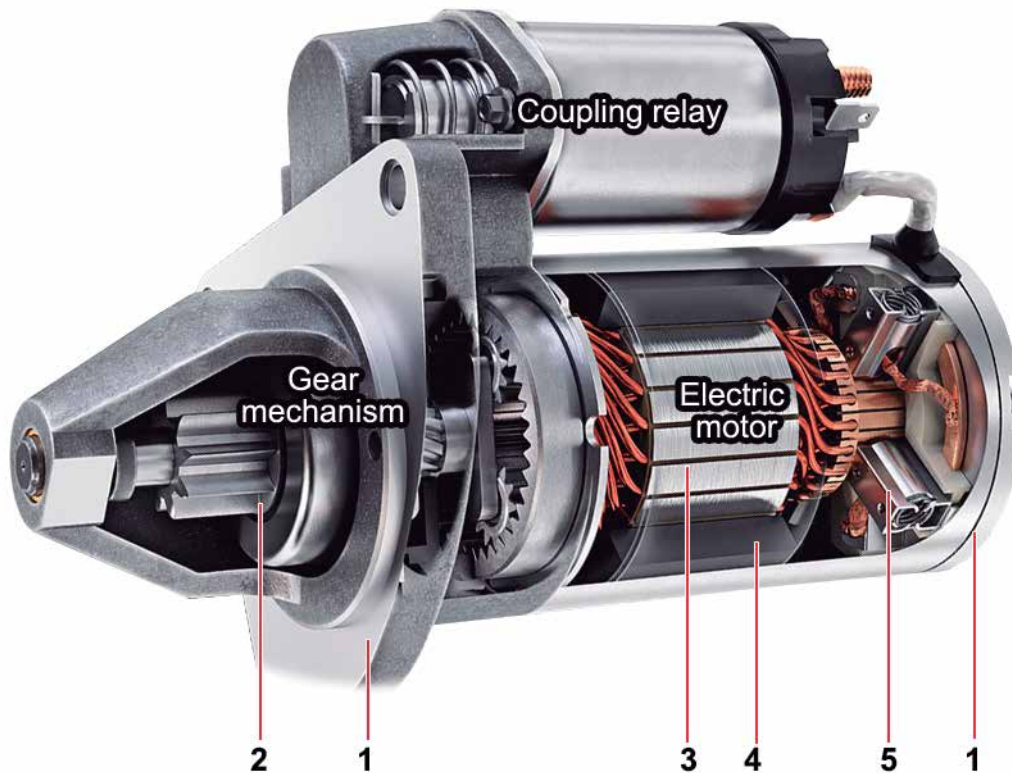

1. **Front and rear housings.** These are fitted with bearings which support the rotor shaft. Furthermore, the front housing incorporates the fixing that holds the starter motor to the engine block.
2. **Sliding pinion with freewheel and coupling lever system** between the gears and the ring gear on the engine flywheel.
3. **Rotor.** It is made up of one or several electrical windings wound on a shaft, with the conductor element rotating inside the magnetic field generated by the stator. The windings that make up the rotor are called induced windings.
4. **Stator.** This is the element responsible for generating the fixed magnetic field. It is anchored to the central housing and can be made up of a permanent magnet or electromagnet. When it is made up of windings (electromagnet), they are called inducer windings.
5. **Brush holder plate.** The brushes are made of carbon and copper. The holder plate keeps them in contact with the rotor collector by means of springs. At least two brushes are necessary, one positive and one negative. The negative is connected to ground through the housing and the positive receives current through the coupling relay.

### Coupling relay

Its function is to move the pinion to engage it with the flywheel ring gear, and to close the electrical contact that allows current to flow from the battery to the starter motor's positive brush or brushes. The purpose of using a coupling relay is to be able to control, with the ignition key

switch or a button, the work of the starter motor by means of a low electric current, which is used to provide, through the coupling relay, a sufficiently large current to operate the starter motor.



## Gear mechanism

This transmits the rotation of the electric motor to the engine with a large reduction in speed and the necessary increase in torque. It is made up of a drive pinion, an actuating rocker arm and, in some cases, an intermediate speed reduction system. The drive pinion moves over

a shaft with helical teeth to facilitate its forward and backward movement when the engine's rpm exceeds that of the electric motor. It also incorporates an overrunning clutch that is blocked in the drive rotation direction and free in the opposite direction (engine started).

## Operating principle

The electrical current flows from the battery's positive terminal to contact 30 of the starter motor. Moving the vehicle's key to the start position supplies power to terminal 50, activating the relay. The actuation of the relay moves the fork that in turn moves the pinion to engage it with the engine's flywheel ring gear, and thus connect the electric motor with the engine. At the same time the relay contacts are closed which allows current to flow to the brushes and the rotor, which creates an alternating polarity magnetic field in the rotor winding that generates

attraction/repulsion with the magnetic fields of the permanent magnets in the housing, causing the rotor to rotate.

Once the engine is started and the key is released, this returns to the ignition position which stops the power supply to the relay. The relay returns to its rest position due to the force of the spring which moves the fork and pinion back to its initial position. At the same time, the contacts are separated which interrupts the current to the rotor and stops the rotation of the electric motor.

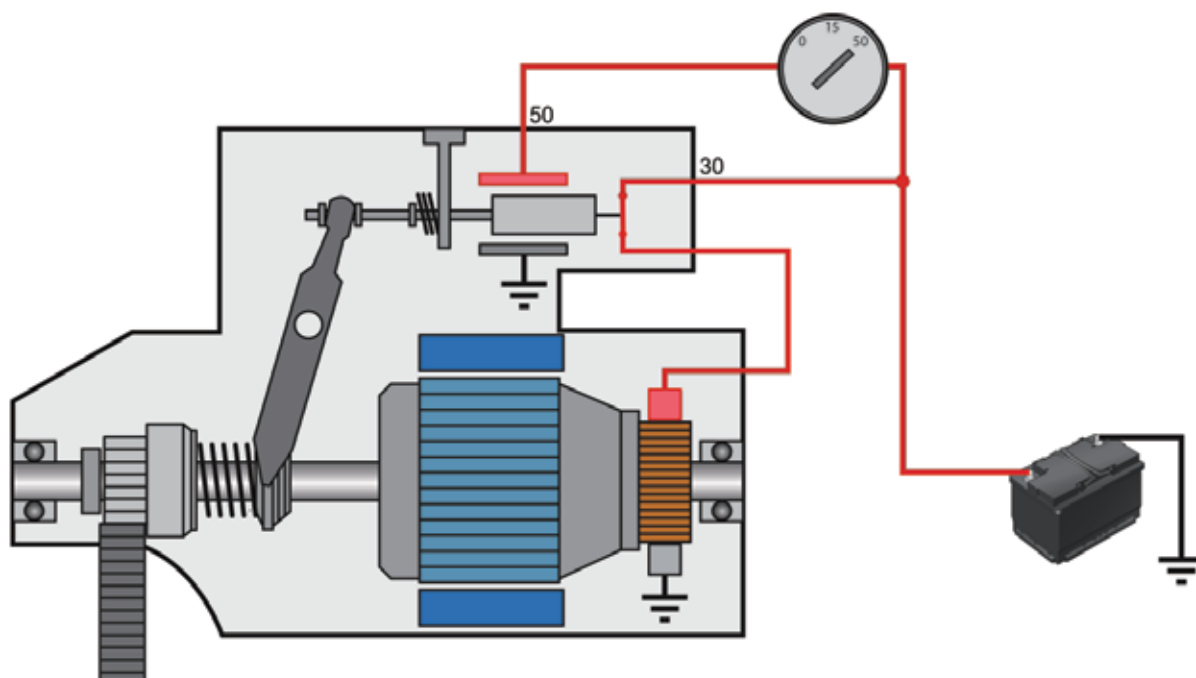

## Technical characteristics

The main reason for choosing direct current electric motors to start the engine is that the battery supplies direct current, as alternating cur-

rent cannot be stored. The most important technical characteristics of a starter motor are as follows:

### Engine torque

The torque of direct current motors at low speed is higher than alternating current motors, especially the initial torque. The force necessary to start the movement of the engine's reciprocating train (pistons-rods-crankshaft) and their connected elements is very large due to the

weight of the components. The size of this resistant force once the rotation is started also depends on the cylinder capacity, the temperature, friction between the internal components and the engine's compression ratio. Normally its value is between 15 and 30 Nm.

### Current consumption

Current consumption during the starting process is very high at the initial moment. Once the starter motor starts to rotate the engine, the current magnitude stabilises at a lower value. Normally, if the engine to be started has a high compression ratio (diesel), the current consumption

can rise up to a peak of 700 amps. On the other hand, in smaller engines (petrol), an initial current peak of some 400 amps approximately will be sufficient.



## Power voltage

Starter motors in passenger vehicles work at low voltage (12 V). The same voltage for heavy vehicles would be insufficient, as the torque necessary to start the engine is so high that the enormous current consumption would cause an excessive drop in voltage in the starter motor's power supply, no matter how low the resistance of the electrical

conductors that connect the battery and the load. For this reason, for lorries and large engines, the electrical circuit operates at 24 V, which prevents the voltage drops during the start-up process as the required current for maintaining the same electrical power factor is lower.

## Starting speed

Engines must reach a minimum rotation speed for fast and reliable starting. Depending on the type of engine, diesel or petrol and its technology, different rotation speeds are necessary for starting. Furthermore, certain external conditions influence the ease of starting of

the engine (ambient temperature, condition and state of charge of the battery, etc.). An old battery or one with a low charge may produce an insufficient rotation force and speed in the starting phase preventing start-up.

## Types of starter motor

Depending on the construction characteristics, transmission of the motion and the coupling system, the following types of starter motor can be found:

### Starter motor with overrunning clutch and fork

This has two or four poles in its inductor circuit, and its coils in series or in parallel or in series-parallel, and with two or four brushes on the collector. The drive system is placed directly on the rotor shaft and is actuated by the control relay incorporated in the motor, by means of the fork.



### Inertia drive starter motor



These are used on small cylinder capacity motorcycles and, sometimes on heavy or stationary machinery. The coupling is achieved by the inertia of the pinion itself when rotation starts and the helical gear on the shaft. It has some similarities with the fork system, but without the forced coupling mechanism (relay, fork and drive mechanism). The current relay in this case is located outside the electric motor and only functions electrically as a remote actuating switch for high currents.

### Gear reduction starter

This is the currently most used starter in medium capacity engines and across-the-board in diesel engines. Depending on the engine cylinder capacity, it may have four or six poles with coils in series-parallel supplied through four or six brushes. The small size of the electric motor allows its rpm to be increased and current consumption to be reduced, while obtaining a lower torque. To increase the initial drive force, a gear unit is fitted between the output shaft and the rotor. In this way, the same starting power is achieved with a more compact and lighter device that also has lower electrical consumption.



# CURRENT GENERATOR

Cars use electromagnetic current generators to supply electrical energy to the many electrical systems in the vehicles. The purpose of these electricity generators is to convert a small part of the mechanical energy developed by the engine into electrical energy. For this, the al-

ternator, via a serpentine belt, receives the rotation motion of the crankshaft via a pulley system that increases its rotation speed with respect to that of the engine.

## Architecture and components

The alternator is made up of:

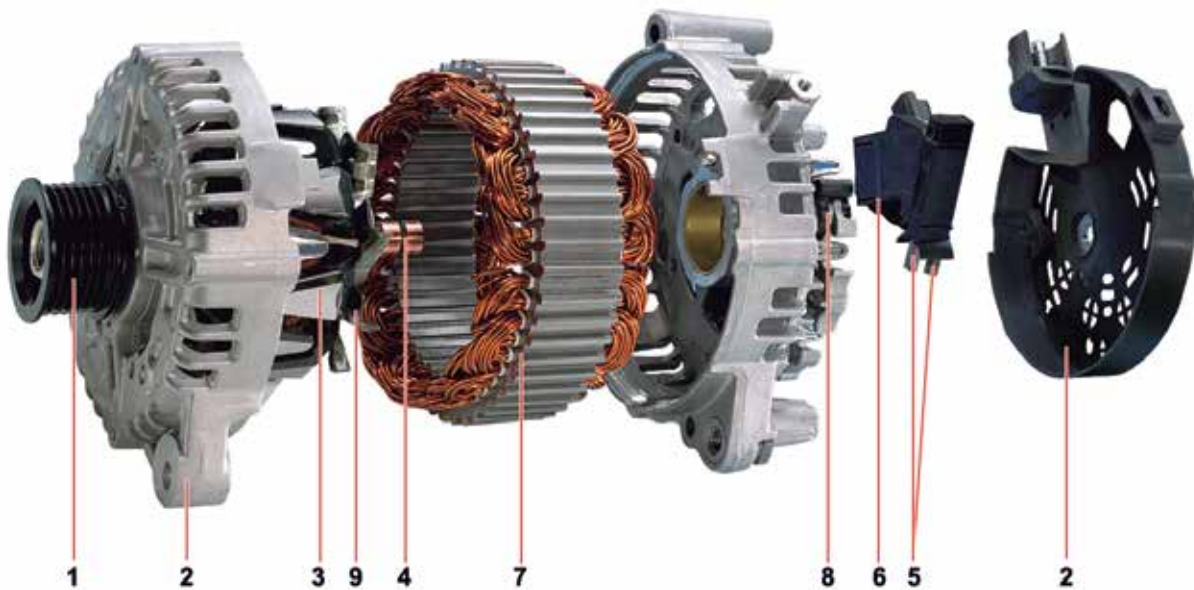

1. **A drive pulley:** it receives the motion from the engine, via a serpentine belt, in order to rotate the magnetic field inside the alternator.
2. **Front and rear housings:** They support the internal elements of the alternator and house the bearings that allow the high rotation speed of the rotor.
3. **Rotor:** This is the central moving part of the alternator, where the induction coil is located that generates the magnetic field necessary for inducing the electrical current.
4. **Slip rings:** These are at the ends of the rotor's induction coil and electrically connect to the outside by sliding contact with the brushes.
5. **Brushes:** There is a positive brush and a negative brush designed to transmit the electrical current to the induction coil (excitation current that produces the magnetic field).
6. **Voltage regulator:** This keeps the alternator's output voltage constant irrespective of the engine rpm. It achieves this by controlling the excitation current, this varies the magnetic field intensity and its induction capacity on the stator coils. Nowadays, the regulators are electronic and are incorporated in the alternator in the majority of cases.
7. **Stator:** This is made up of copper coils fixed to the alternator's intermediate housing. The variation of the position of the magnetic fields generated by the rotor with respect to the stator induces an alternating polarity current at the ends of the coils.
8. **Diode board/rectifier bridge:** This device converts the alternating current induced in the stator into direct current. The direct current can be stored in the battery and is also necessary for the work of the electronic components based on semiconductors.
9. **Fan:** This is a finned disc designed to suck in air and force ventilate the inside of the alternator to prevent excessive temperatures that could damage its components.

## Operating principle

When the engine is running, the serpentine belt transmits the rotation motion of the crankshaft to the alternator via a pulley, which generates a current by electromagnetic induction.

The alternator rotor is made up of two polar parts arranged opposite each other and a copper wire coil, which, when supplied with direct current, continuously generates multiple magnetic fields of opposing polarities around it.

The variation of the magnetic field on the stator coils induces a continuously varying and alternating polarity potential difference at the ends of the stator.

The electricity generated in the stator coils is conducted to the rectifier bridge and voltage regulator. The rectifier bridge is the component that converts the induced alternating current into direct current using diode pairs that only allow electron flow in one direction.

The voltage regulator adjusts the current supplied to the rotor to achieve the correct output voltage or supply. It ensures that the current is constant and there are no peaks, and that it is not excessive when the engine rpm varies. It also generates the current necessary to supply the electrical needs of the vehicle and charge the battery if it is not completely charged.

## Electronic control of alternator charging

In the majority of modern vehicles, the alternator's work is regulated electronically to optimise the performance of the electricity generation and storage system, thus achieving greater energy efficiency of the vehicles.

The alternator is controlled with specific energy management software that controls the variable charging voltage of the vehicle. As the alternator output voltage varies, the current supplied by the alternator or the battery is regulated; a partial discharge of the battery is allowed under certain operating conditions and it regulates the charging current.

This software can be implemented in a control unit called the power

supply control unit, in the on-board power supply control unit or even in the engine control unit, depending on the manufacturer and the vehicle's equipment.

The strategy for the optimised energy control of the vehicle includes taking advantage of the vehicle's braking and the times of low demand for engine torque to regulate the alternator at a higher current generation level. Otherwise, when the engine torque demand is high, for example during acceleration, the alternator's charging regulation is lower or even nil, and it supplies the battery with the current necessary for the operation of the vehicle's electrical systems at that time.

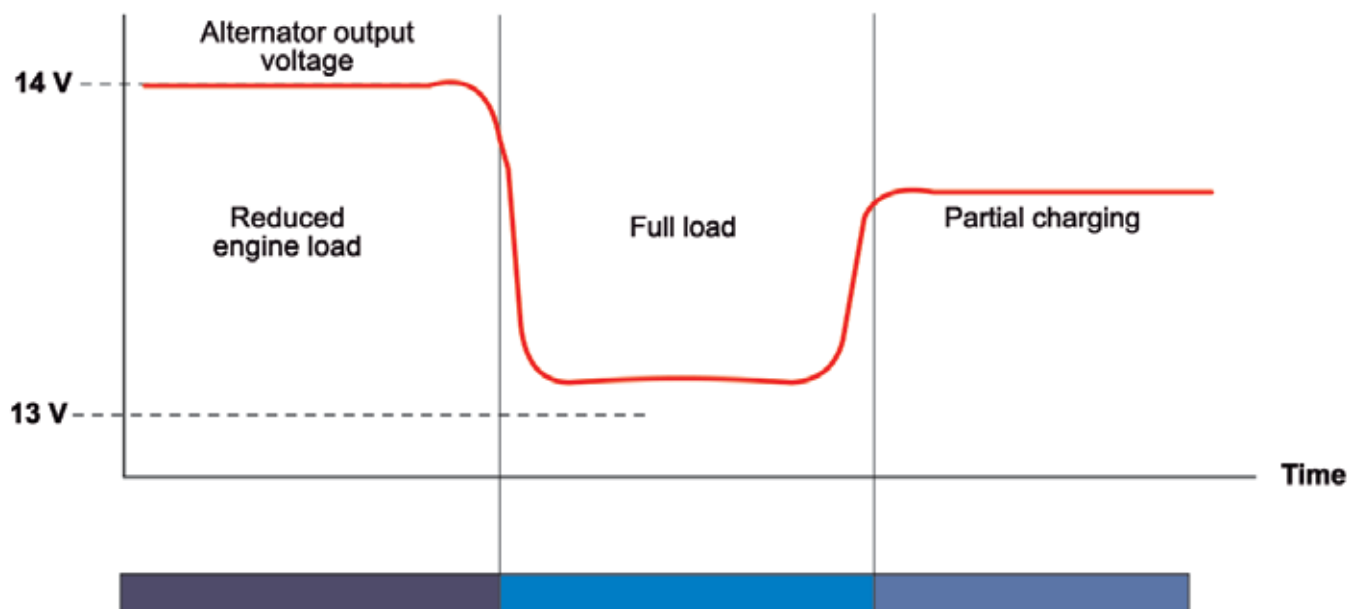

The temperature of the battery and its electrolyte are also a fundamental factor in the electrical energy management of the vehicle. A specific sensor continuously monitors this parameter so that the management

software can regulate the charge in a more progressive and less intense way which prolongs the life of the battery.

## Technical characteristics of generators

The selection of alternators for different vehicles is determined by their construction and functional characteristics: low weight and small size, compact design, resistance to vibrations and high temperatures, conversion efficiency and delivery of charging current from low engine rpm. Precise control of the voltage of the generated current is also very important. The current that an alternator can provide when rotating at different speeds is represented by characteristic curves, which are always referred to a constant predefined temperature and voltage.

When replacing the alternator, the technical characteristics must always be considered and complied with. For this, the data stated on the manufacturer's specification label must be interpreted. It usually states the nominal working voltage, the maximum generated current and the identification of the electrical terminals on the alternator for connections, in addition to the manufacturer's commercial information (make, part number, model, etc.).

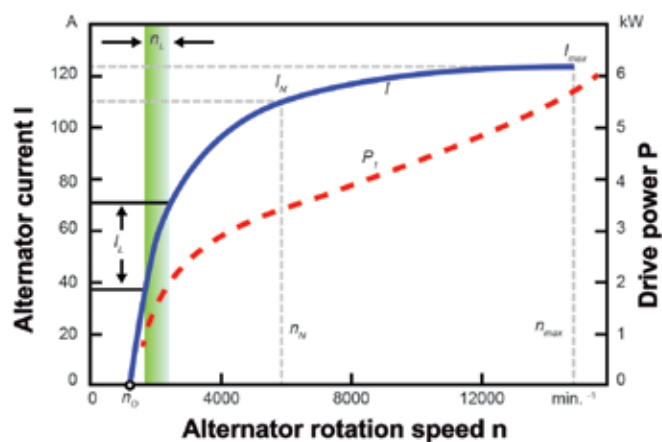

## Types of generators

The operating principle and the main components are largely common to all alternators. The main possible differences lie in construction details and in technical characteristics such as the generated voltage, the maximum current and power delivery according to the

speed of rotation. In line with these points, the rotor will be equipped with a certain number of poles and have a specific electrical design. The most common types of alternators are as follows:

### Claw pole alternators with slip rings

The construction of these alternators makes the generator a compact unit with a good power output and low weight. It has a wide range of applications (passenger cars, industrial vehicles, tractors, etc.). The name "claw pole" reflects the way in which the magnetic poles are arranged. The rotor shaft carries the two polar wheel halves with opposing polarity. Each half is equipped with poles in the form of claws linked together to alternatively form the north and south poles. In this way, they cover the excitation winding, in the form of an annular coil, arranged over the polar core. The number of possible poles can be between 12 and 16.

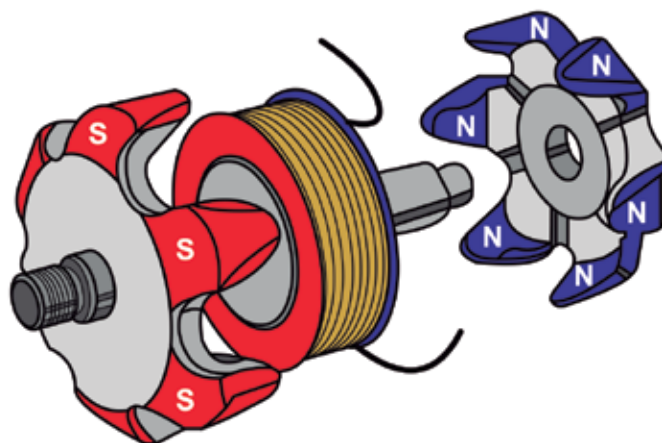

### Salient pole alternators with slip rings

These are usually used in vehicles with a high electrical demand (> 100 A) and battery voltages of 24 V. They are suitable for buses, vehicles on rails, boats and large special vehicles. It has individual

poles instead of a rotor with claws. It has four or six individual poles on which the excitation winding is directly applied.

### Alternators with rotor-guide without slip rings

They are usually used in special powerful vehicles such as construction machinery, long-distance lorries, etc. These alternators do

not have slip rings, brushes or other wearing parts except the bearings. They are very strong and are practically maintenance free.



## Compact alternator with liquid cooling

Engine coolant is used to cool the inside of the alternator through a sealed cavity. This technique improves the noise and heat dissipation disadvantages of air cooled (turbine) alternators. This new system increases soundproofing and has good cooling. Furthermore, in cold conditions this technology helps the engine to reach its working temperature sooner, thanks to the heat that the alternator absorbs, helping to reduce pollution.



# START-STOP SYSTEM

## Description

Air pollution in large cities is one of the major environmental and health problems at a global level. It is obvious that the proliferation and intensive use of vehicles with combustion engines is mainly responsible for this pollution.

The pollution produced by vehicles driven by combustion engines can be divided into three groups: emissions of gases harmful to health, emissions of greenhouse gases (carbon dioxide and hydrocarbons) and noise pollution (also harmful to health).

These 3 pollution levels can be reduced by incorporating Start-Stop systems that improve the energy efficiency of vehicles by performing the following actions:

- Automatic stopping and starting of the engine while the vehicle is stopped at a traffic light or stop sign.
- Recovery of the kinetic energy of decelerations and braking by storing it in the battery.

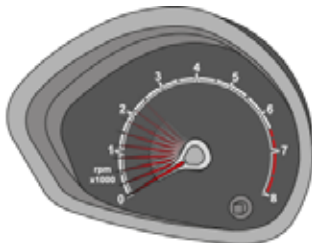

Introduced on a mass scale by the majority of car manufacturers from 2010, Start-Stop systems with their specific functions entail a series of changes in the starting and charging systems and the

distribution of the electrical supply in vehicle. The new and evolved components necessary for carrying out the Start-Stop functions are:

### The battery

Although it looks similar to a conventional battery, the internal technology of batteries for Start-Stop systems is necessarily different. They are normally VRLA batteries of the AGM type. They have been designed to withstand more charging and discharging cycles due to the higher number of expected starts. Furthermore, the charg-

ing mode applied is different; it maintains the battery at 80% of its capacity to take advantage of deceleration situations to store the electrical energy in the remaining 20%.

## Battery current sensor

This is a current probe installed on the battery's negative cable. This sensor records the magnitude and direction of the current input and output (charging-discharging) in the battery. It allows the capacity and state of health of the battery to be calculated when the electrical system is significantly discharging the battery and when it is at rest. In the event of a significant discharge, the effective recovery of the battery will be decisive for the Start-Stop system to be able to be used without risk, ensuring that the engine restarts.



## Alternator



They have evolved to be equipped with slave communication and control electronics of an external control unit. The external control unit determines the excitation level of the rotor and demands information from the alternator electronics on the current magnitude generated by the stator as a feedback signal.

## Starter motor

Now they are lighter and more compact. Their advanced construction makes them more reliable, as they must be designed to carry out many more working cycles than a starter motor for a vehicle without Start-Stop.



## Voltage stabilisers

These devices are necessary for compensating the voltage drop caused by the starter motor when starting the engine. Without a voltage stabiliser, every time the engine is started, a drop in the power supply voltage would occur in the vehicle's electrical system equipment active at that time. Over time, this would lead to disruption and damage mainly in the vehicle's multimedia systems (radio, navigator, screens and electronic units in general). Previously, voltage stabilisers were not necessary as it was not originally planned that the vehicle's electrical equipment would be connected at the beginning of the driving cycle or before starting the engine. Further-

more, generally there was only one start per driving cycle. With the incorporation of the Start-Stop function, the amount of starts in each driving cycle has increased by ten or twenty, making it necessary to stabilise the voltage during each start-up of the same driving cycle to ensure the uninterrupted operation of the vehicle's electrical equipment, thus preventing damage.

The manufacturers of vehicles with combustion engines have seen in the Start-Stop system a development line of moderate cost that improves the efficiency of their vehicles on the road, and at the same time it reduces polluting emissions during urban driving.



## Operating strategy

The main objective of the Start-Stop system is to reduce fuel consumption and with it, polluting emissions. The system's working strategy requires the fulfilment of a series of basic requirements that allow it to be activated. These requirements are listed below:

- The system must be active and not purposely switched off by the driver by means of the off switch.
- The operating temperature of the engine must be above a minimum value.
- The battery must have a sufficient state of charge for starting.
- The driver's door and engine compartment must be closed.
- The driver's seatbelt must be fastened.
- The required temperature in the cabin must have been reached by the climate control unit.
- The vacuum level in the brake servo must be sufficient to ensure braking under normal conditions.
- The vehicle must not be parked on a gradient greater than 10% or carrying out parking manoeuvres.
- Large electrical loads such as heated windows, windscreen wipers etc. must be off.
- In the case of diesel vehicles, the anti-pollution system must not be carrying out a particulate filter regeneration, as the engine must not stop during the removal of the particles until regeneration is complete.

If these basic requirements are met, the Start-Stop system is ready for operation. Its strategy is to stop the engine when it is not required, so it waits for this situation to occur.

### How does the system detect the appropriate moment for stopping the engine?

The system software constantly monitors certain parameters. If the speed drops to 7 km/h (overall value), when the gear lever is put in the neutral position and if the clutch pedal is pressed or released. In the case of an automatic gearbox, the system will react when it receives the pressed brake signal. When the signals are processed, the system stops the engine and at the same time indicates that it is an automatic stop by switching on the Start-Stop warning light on the instrument panel, so that the driver does not think that the engine has stalled or stopped accidentally. It is important to remem-

ber that the engine may be stopped even when the vehicle is not completely stationary if its speed is under 7 km/h. This very slow speed (slightly faster than a gentle walk) is considered a clear sign of the intention to stop the vehicle, as it would be inconsistent with normal driving conditions.

### How does the system detect the moment that it must start the engine?

The moment to start the engine is recognised when the driver fully depresses the clutch. If the pedal is not fully pressed down, the engine may not start even if a gear is selected and engaged. In the case of automatic gearboxes, the engine is started when the brake pedal is released or a gear is selected by moving the gear lever.

The system may start the engine before the driver decides to continue driving by pressing the clutch (or before releasing the brake in the case of an automatic gearbox). The early start-up of the engine is carried out for the following reasons:

- The battery has lost charge due to the energy demand of the electrical equipment during the automatic stop. The Start-Stop software calculates the early start-up moment so that there is still sufficient energy to ensure the engine can be started.
- The vacuum in the brake servo drops putting the braking assistance at risk. Consequently, the Start-Stop starts the engine so that the vacuum generated by the engine compensates the loss of vacuum in the brake servo.
- The engine stop time is exceeded. To prevent the cooling of the exhaust gas treatment system, the system calculates the start-up moment.
- The vehicle starts to move because it is on a slope. To prevent the vehicle moving when the engine is stopped and there is no possibility of traction, the system starts the engine.
- If the windscreen wipers are operating at maximum speed, the system calculates when to start the engine and thus compensate the electrical energy demand.
- A temperature is requested in the cabin that can only be satisfied by running the engine (heating or air conditioning).

### Warning!

- The vehicle should never be left without manually switching off the engine.
- In those vehicles with a robotised gearbox, the brake pedal should not be released while on a slope, it is recommended that the engine is started by moving the gear lever.
- Never refill with fuel while the Start-Stop system has stopped the engine, as it could start at any moment.
- When the climate control comfort in the cabin is a priority for the driver, the Start-Stop function should be switched off.
- If the vehicle is not equipped with a bonnet switch or it is defective, hands should not be placed in this area due to the risk of the engine starting. Therefore, before working in the engine area, the system must be switched off or the engine stopped manually.

# REVERSIBLE ALTERNATOR

## Description

This is a component designed to generate electrical energy and function as an electrical motor, with the capacity to start the engine when the Start-Stop system is activated. The system is manufactured by Valeo and it is applied in vehicles, for example, of the PSA group with the commercial name i-StARS.

The main components of the system are the reversible alternator -1- and the power module -2- that controls it.

This alternator is a synchronous generator with claw rotor and cooling by means of air circulation. The power module is located next to the engine cooling radiator, so it is near the alternator which re-

duces the amount of wiring between them. The main functions of the module are: to manage the system, to control battery charging, to convert the generated three-phase current into single-phase direct current for the electrical supply to the vehicle, and carry out the change of function of the alternator to starter motor.

For the starting function, the exact position of the rotor must be known in order to be able to determine which phase must be provided with a voltage to start the movement. For this, there are a series of position sensors in the rear section.

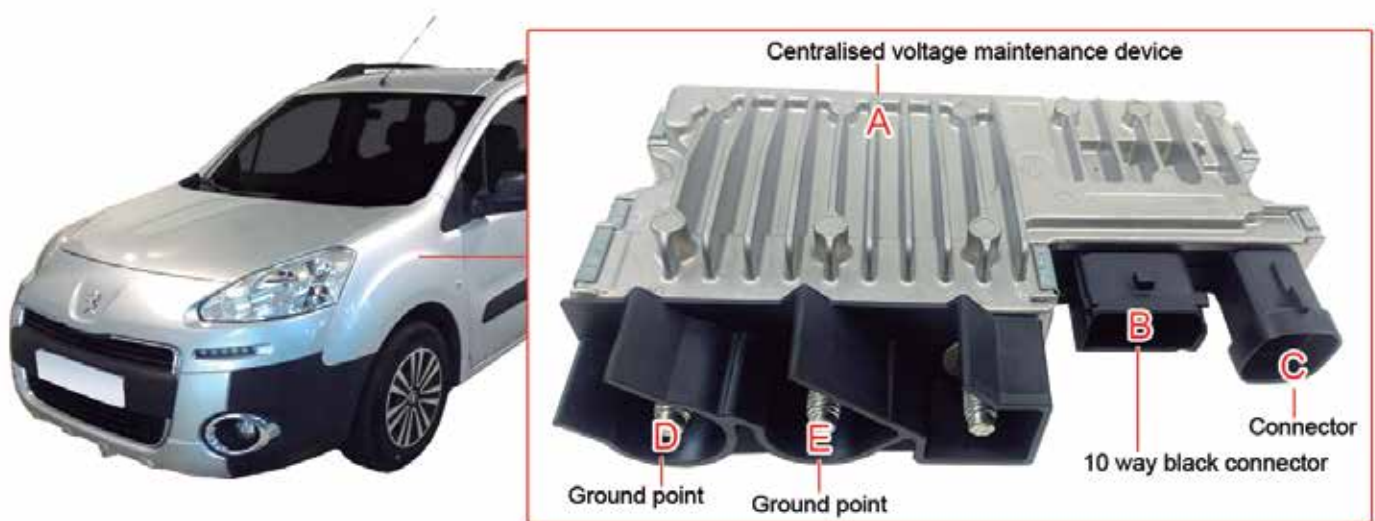

As the system has evolved, a capacitor has been introduced, which stores energy during vehicle deceleration and delivers it in one go at the beginning of the engine start-up. This reduces severe battery discharges and makes it possible to use conventional batteries.

A special, Micro-V high torque belt has been designed to withstand the demanding engine starting function for more than 600,000

starts. In the 2nd generation, there are two tensioners specifically for the system, it has a lower tension level in the belt which ensures maximum efficiency and minimisation of friction losses in the belt transmission system.

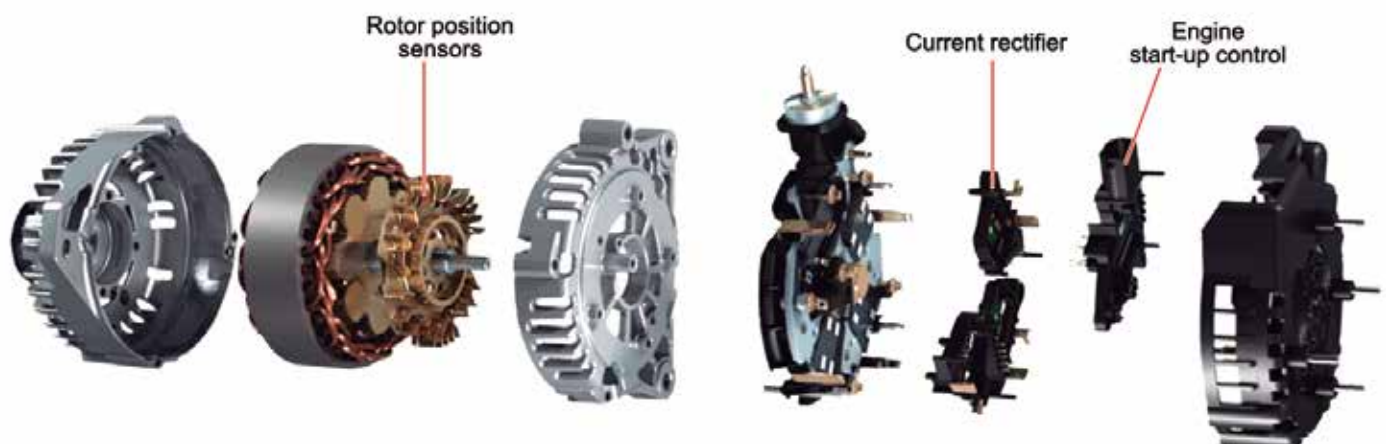



## Operating principle

The operation of this system is divided into two modes: start and alternator.

**Start mode:** this is the starting mode. The electronic converter provides three currents offset by 120° according to the information from the alternator's three position sensors, and can deliver a current of 600 A. With this, the engine is actuated at a high-power (2.5 kW at 14 V) and at a higher speed than a conventional start-up. Immediately after, alternator mode is switched on.

**Alternator mode:** The electronic converter uses MOSFET field-effect transistor technology for rectification of the three-phase current, which is why this type of alternator has an efficiency of 82%, 10% higher than a traditional alternator. The current delivered in this phase is up to 80 A.

The manufacturer and the end user benefit from this technology, the advantages can be summarised as follows:

- Consumption and CO2 emissions are reduced.
- Stopping and starting of the engine are automatic.
- The engine can be started while it is stopping.
- The motor is started immediately, silently and without vibration.
- Electrical efficiency is higher than that of a conventional alternator.
- The installation on the engine block and electrical integration are simple.
- The length of the power train does not increase, in contrast to an alternator with normal starter motor.

## COMMON FAULTS

### Battery

The useful life of the battery is conditional upon various factors such as: the number of starts, the charging-discharging cycles, the exterior temperature, the use and type of driving of the vehicle, the age of the battery, etc.

Extreme heat can generate sulphation and corrosion inside the battery. This problem is more notable when it is cold, it is difficult to start the engine. If the vehicle is left parked for a long period (more than 2 months) the battery may go completely flat. On the other hand, if the vehicle is only used on short journeys, the alternator does not have time to fully recharge the battery, therefore it will go

flat quickly, especially at low temperatures.

As a general rule, batteries usually last for 5 years with normal use. After this time, they start to lose power until they are completely degraded. When the battery is flat due to discharging, it can be solved in the majority of cases with a good charge. Otherwise, if it is unrecoverable (sulphated, short-circuited, broken, etc.), it must be replaced. There are electronic testers on the market that help to diagnose the state of the battery.

### Starter motor

The most common faults that a starter motor may have are: no activity although the starter switch is operated, the starter motor knocks but does not couple, or the rotation of the starter motor can be heard but it has no effect, etc.

The starter motor may fail for different reasons, such as: electrical connection problems, faults in the starter relay, anomalies in the electric motor, or damage in the coupling system (gearing with free-wheel, pinion or freewheel), etc.

Depending on the symptom, it may be best to use the multimeter, clamp ammeter or to inspect the component in search of noise or visible deterioration. In the case of a possible mechanical or electrical failure of the starter motor, in the majority of cases it is replaced, although there are specialists that repair them and sell them as an exchange part.

### Alternator

# TECHNICAL NOTES

This section describes the most common malfunctions related to starting and charging systems. Depending on the manufacturer and the different models, the number of faults occurring over the years may vary.

These faults are selected from the online platform: [www.einavts.com](http://www.einavts.com). This platform has a series of sections that specify: make, model, line, system affected, and subsystem, which can be selected independently depending on the desired search.

## FORD

Symptom	<p>B1318 - Battery voltage low.          B1602 - INMO Transponder signal invalid.          B1681 - Immobiliser receiver coil. No signal.          B2103 - Immobiliser receiver coil. No connection.          B2139 - Passive anti-theft system immobiliser signal not recognised.          B2286 - Inertia switch failure.          U1900 - CAN BUS communication failure.          U2200 - Mileage data invalid.          U2510 - CAN communication BUS fault Reception error.          Engine will not start.          Improper starter motor operation. The starter motor does not operate.          Injection fault messages on the instrument panel.          Battery discharged and has possibly been replaced previously.</p>
Cause	<p>Loss of memory of the immobiliser control unit.          The battery may have been changed on one occasion and the immobiliser control unit lost the stored memory.</p>
Solution	<p>Re-programme the immobiliser unit with updated software.</p>

## AUDI

AUDI A3 (8P1) 1.6 TDI (CAYC)	
Symptom	<p>The engine does not start in Start-Stop mode and no fault codes are reported.          The following symptoms are observed in the workshop:</p> <ul style="list-style-type: none"> <li>• The engine initially starts properly but when it stops in Start-Stop mode and the clutch pedal is pressed to start the engine, it does not start.</li> <li>• The battery is replaced and coded but the Start-Stop system does not work.</li> </ul>
Cause	<ul style="list-style-type: none"> <li>• Defective battery.</li> <li>• Battery coding not carried out.</li> <li>• Road journey not carried out.</li> </ul>
Solution	<p>Repair procedure:</p> <ul style="list-style-type: none"> <li>• Replace the battery.</li> <li>• Code the battery with the diagnostic tool following the steps below (they may vary depending on the diagnostic tool used):              Go to 'Electrical energy management', then 'Adjustments/Settings', then 'Battery change' then 'Start function'.</li> <li>• During this step you can see that we are asked for a series of variables that must be entered manually:</li> <li>• 3 digits of the battery make (select on the menu of the diagnostic tool itself).</li> <li>• 3 digits of the 'Battery capacity' (e.g. 090 for a battery of 90 Ah capacity).</li> <li>• 10 digits of the battery serial number.</li> <li>• End.</li> <li>• Carry out a road journey of between 15 and 20 km.</li> </ul>

## PEUGEOT

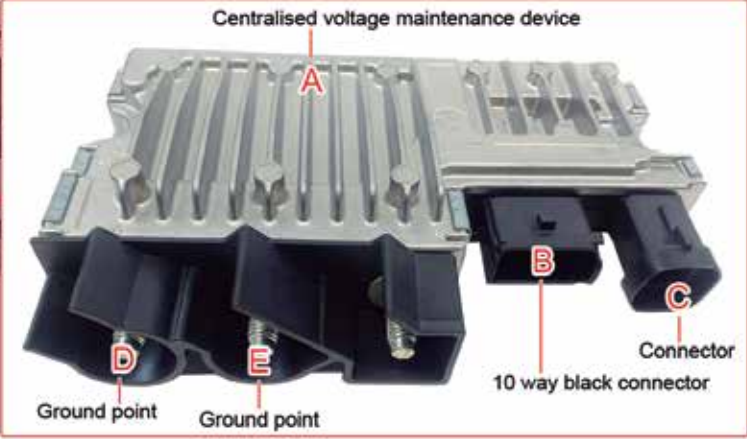
308 SW 1.6 HDi (9HR (DV6C)) - 301 1.6 HDi 90 (9HF (DV6DTE)) - PARTNER Tepee, Van, Body/Chassis 1.6 HDi (9HF (DV6DTE))	
Symptom	<p>'ECO' and 'SERVICE' warning light flashing on the instrument panel.            Fault message on the multifunction screen: - 'Repair the vehicle'.            One or more fault codes recorded in the engine control unit:</p> <ul style="list-style-type: none"> <li>• U1133 - Local interconnection network (LIN). There is no communication.</li> <li>• U1134 - Local interconnection network (LIN). There is no communication.</li> <li>• U1400 - Local interconnection network (LIN). Error in communication.</li> </ul> <p>Inoperative function of the Start-Stop system.</p> <p><b>NOTE:</b> This newsletter only affects those vehicles equipped with a Start-Stop system with a reversible alternator (Alternator-starter).</p>
Cause	<ul style="list-style-type: none"> <li>• Defect of the electrical wiring of the centralised voltage capacitor.</li> <li>• Defect of the centralised voltage maintenance device.</li> <li>• Defect of the reversible alternator.</li> </ul>
Solution	<p>Repair procedure:</p> <ul style="list-style-type: none"> <li>• Read the fault codes reported by the engine control unit with the diagnostic tool.</li> <li>• Confirm that one or more of the aforementioned fault codes are recorded.</li> <li>• Confirm that the aforementioned symptoms are reproduced.</li> </ul> <p><b>Carry out the following procedure if only fault code U1134 appears:</b></p> <ul style="list-style-type: none"> <li>• Check the continuity of the LIN line between pin No. 10 of the black 10 way connector 'B' of the centralised voltage maintenance device 'A' and pin No. 49 of the black 53 way connector of the engine control unit, and repair wiring if necessary.</li> <li>• Check the continuity of the LIN line between pin No. 9 of the black 10 way connector 'B' of the centralised voltage maintenance device and pin No. 37 of the black 53 way connector of the engine control unit, and repair wiring if necessary.</li> <li>• Check for a 12 V voltage on pin No. 7 of connector 'B' of the centralised voltage maintenance device, repair if necessary.</li> <li>• Check for a 12 V voltage on connector 'C' of the centralised voltage maintenance device, repair if necessary.</li> <li>• Check the ground at points 'D' and 'E' of the centralised voltage maintenance device, repair if necessary.</li> <li>• Check the pins of the connectors that connect the centralised voltage maintenance device, repair if necessary.</li> <li>• Replace the centralised voltage maintenance device if all the above checks are satisfactory.</li> </ul> <p><b>Carry out the following procedure if fault codes U1134, U1113 and 1400 appear together:</b></p> <ul style="list-style-type: none"> <li>• Disconnect the black 5 way connector from the reversible alternator.</li> <li>• Check if fault code U1134 disappears.</li> <li>• Replace the reversible alternator if fault code U1134 disappears.</li> </ul> <div style="display: flex; align-items: center;">  <div style="border: 1px solid red; padding: 5px;"> <p style="text-align: center; margin: 0;"><b>Centralised voltage maintenance device</b></p>  <p style="text-align: center; margin: 0;">Ground point      Ground point</p> <p style="text-align: right; margin: 0;">10 way black connector</p> </div> </div>



EureTechFlash aims to demystify new technologies and make them transparent, to stimulate professional repairers to keep pace with technology.

Complementary to this magazine, EureTechBlog provides weekly technical posts on automotive topics, issues and innovations.

Visit and subscribe to EureTechBlog on [www.euretechblog.com](http://www.euretechblog.com)



The technical competence level of the mechanic is vital, and in the future may be decisive for the continued

existence of the professional repairer. headquarters in Kortenberg, Belgium ([www.ad-europe.com](http://www.ad-europe.com)). The Eure!Car program contains a comprehensive series of high-profile technical trainings for professional repairers, which are given by the national AD organizations and their parts distributors in 48 countries.

existence of the professional repairer.

Visit [www.eurecar.org](http://www.eurecar.org) for more information or to view the training courses.

Eure!Car is an initiative by Autodistribution International, with

industrial partners supporting Eure!Car

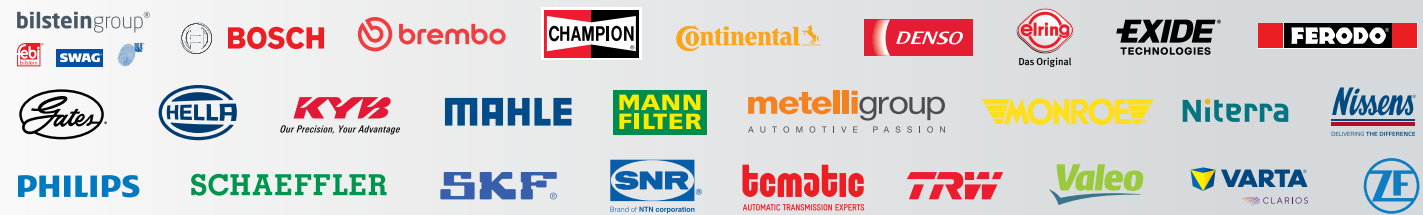

# Injection Systems with LPG and CNG



**Disclaimer :** the information featured in this guide is not exhaustive and is provided for information purposes only. Information does not incur the liability of the author.